

Installation Instructions

00709000 Backstop Winch

Caution

- 1 – As with any lifting device, the installation shall be made only by persons suitably experienced and qualified for work on hoisting equipment, in accordance with local requirements.
- 2 – The electrical supply and connection to the winch shall be made in accordance with local electrical code and by qualified personnel.
- 3 – The instructions address the areas of proper mounting, rope installation, wiring and limit switch adjustment, but they are not intended to cover every aspect of installation of your hoisting system, not to replace the need for normal good care, workmanship and proper practices on the part of the installer.

Mounting winch on a flat surface

- 1 – Four 9/16" diameter holes are provided for mounting the unit. The fastener type and size required will vary according to the type of mounting surface but must be adequate to safely sustain all loads imposed by the backstop.

Mounting winch to a pipe

- 1 – Use the two pipe clamps supplied to secure the winch to a 3 1/2" O.D. standard pipe. The use of clamps for 4" O.D. pipe is also provided for on the side base plates of the winch. The pipe clamps will line up with the two pairs of mounting holes on the front flange of the winch (see fig. 1).
- 2 – Use the nuts, bolts and washers provided in the kit. The winch may be mounted with the rope port (s) up, down or sideways because there are no lubricant levels to be concerned with or oil to drip. Two rope ports are provided and either one may be used to bring the rope out to suit your installation arrangement.

Please Note: Do not over tighten U-bolts if used; over tightening can cause deflection and weakening of the bolts, and damage the unit.

- 3 – Use provide 1/2" u-bolts and muffler clamps to attach the winch to 3 1/2" O.D. pipe.

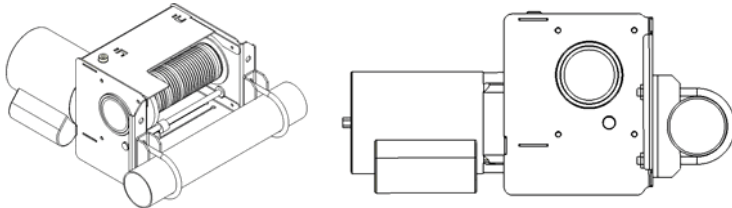

Figure 1

Winch wiring (see wiring diagram on page 2)

- 1 – Winch comes prewired with a plug or two 7/8" diameter knock-outs are provided, one on each side of the winch, to accept 1/2" conduit connectors and provide wire access to the electrical compartment at the bottom of the winch case.
- 2 – Remove the two screws securing the lower cover, slide the cover out from its locating tabs and withdraw it.
- 3 – The wiring diagram is on the inside surface of the cover. Field connections are made directly to the terminal block provided. We recommend using a minimum of 12-gauge conductor wire as a power supply line to the winch. All circuit breakers must be dedicated. Check for voltage drops under load. (The limit switches are located in the same compartment.)

DO NOT USE LONG EXTENSION CORDS TO POWER THE WINCH. USE A MINIMUM OF 14/3 GAUGE MAXIMUM 100 FT WHILE INITIALLY CONNECTING THE WINCH DURING INSTALLATION PERIOD. RUNNING THE WINCH UNDER BAD POWER-VOLTAGE CONDITIONS WILL RESULT IN OVERHEATING AND DAMAGE TO THE CAPACITORS.

Please note: The winch limit switches are pre-wired at the factory. Do not test run the winch with the limit switches bypassed as this may cause over-travel of the limit mechanism and result in damage to the winch.

Wire rope installation (see Fig. 2)

The winch is designed for standard 1/4" diameter 7 x 19 aircraft cable. The rope passes through a hole in the drum and is prevented from pulling out by doubling the end back on itself and securing with a standard rope clamp.

- 1 – Jog the winch to bring wire rope mounting hole in winch drum to the top.
- 2 – Pass the wire rope from outside the winch in through the rope port and then through the hole in the drum into the center of the hollow drum. Pass enough cable through to allow pulling the free end out the end of the drum.
- 3 – Double the cable end back on itself and install the cable clamp supplied. Tighten nuts progressively to make sure that the clamp is fully secured.
- 4 – Pull the rope back through the hole to bring the clamp back tight to the hole inside the drum.
- 5 – Run winch in the "up" direction. The rope runs straight out from the starting side of the drum to the head pulley so that there will be an angle on the rope when the backstop is UP. This helps pull the rope away from the end flange if a second layer of winding is needed.

Please Note: Put only two turns of rope on the drum at the start of the lift. Too many turns uses too much of the drum and may force the rope to go onto a second layer when it is not needed.

- 6 – Run the free end of the rope through the rigging system and attach it to the backstop attachment point.

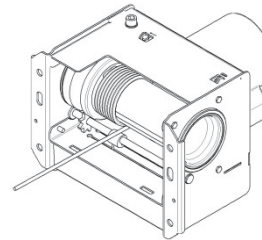

Rope must be wound on the drum in this direction

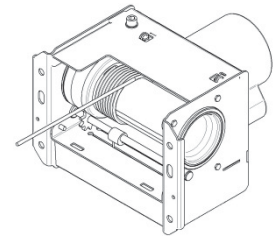

Rope wound in wrong direction

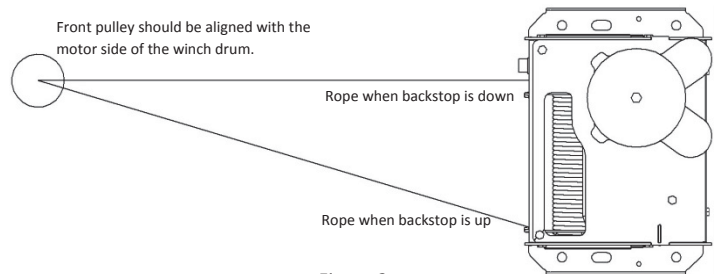

Figure 2

PORTER

601 Mercury Drive
Champaign, IL 61822-9648
USA (800) 637-3090

INST00709

Limit Switch Adjustment

Please Note: One upper and one lower travel limit switch is provided. Proper adjustment is simple and quick with the following procedure. Always shut power off from the winch when working inside the electrical compartment. The cover has been designed for quick removal to simplify limit switch adjustment.

- 1 – Run the winch in the “up” direction to raise the backstop to the desired (fully raised) position and stop it in this position. Turn off the power to the winch and remove the electrical compartment cover. (2 screws)
- 2- Loosen the two thumb nuts holding the upper limit switch.
- 3 – Slide the upper limit switch across until the blade contacts the limit rod, then slide it a little further until an audible click is heard as the switch opens. Tighten the thumb nuts. The top limit is now set.
- 4 – Temporarily install the cover and run the backstop down to the desired lower stop position and set the lower limit switch the same way.
- 5 – Run the backstop up and down again to check the settings
- 6 – Make a final check to make sure that all fasteners are tight and the rope is tracking properly in the drum grooves before putting the winch into use.

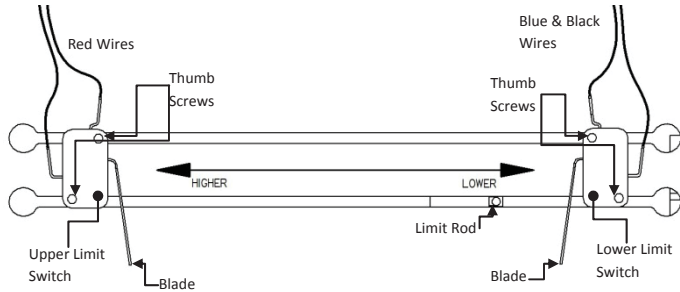

Emergency Lowering of Backstop in Case of Power Failure

If the winch is not able to be used because of a power failure, etc., it is possible to turn the winch manually to lower the backstop.
 The winch motor comes standard with a ½” hex on the end of the shaft at the back of the motor
 Use a ½” socket and a cordless drill or hand tools over the hex shaft.
 Turning the shaft clockwise will slowly lower the backstop.

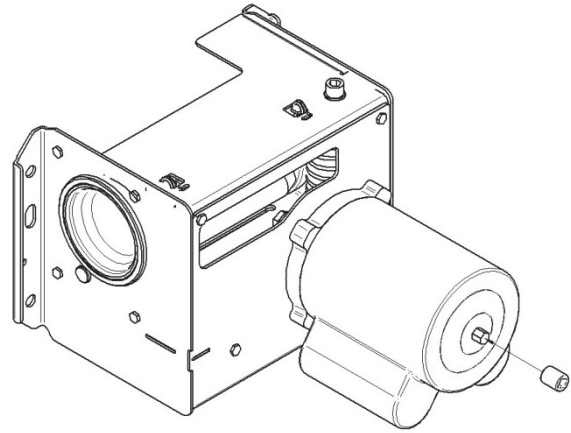

709 Details and Dimension

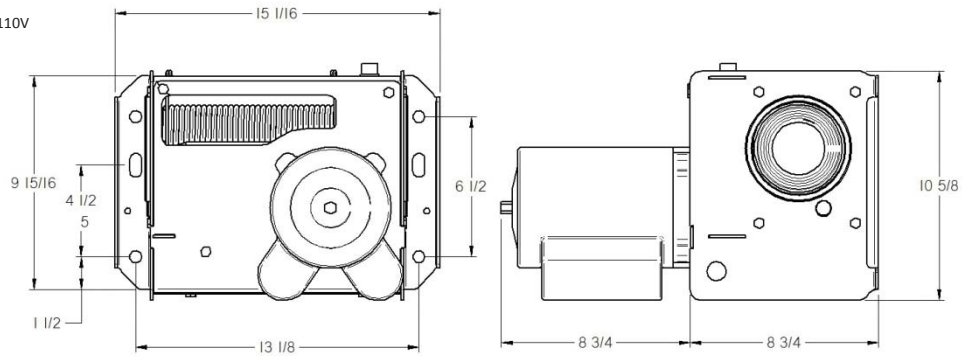
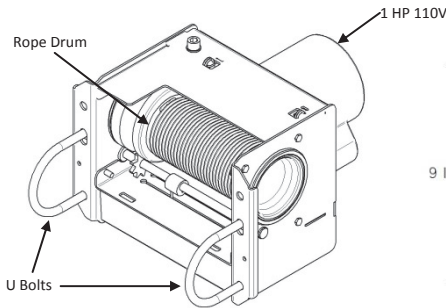

Please Note: Do not over tighten U-Bolts if used; over tightening can cause deflection and weakening of the bolts, and damage to the unit.

Wiring Diagram

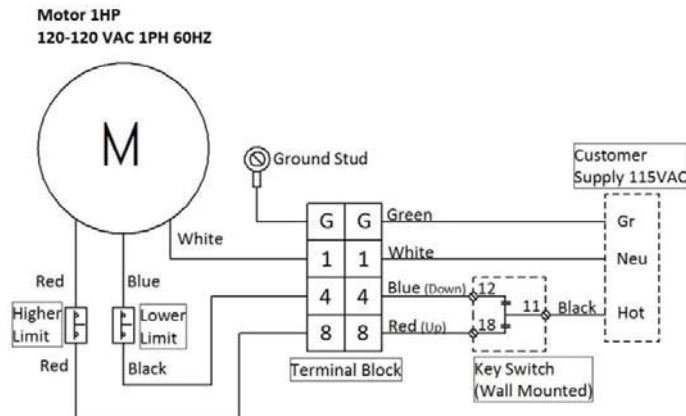

WARNING: Cancer and Reproductive Harm –
 For more information go to www.p65warnings.ca.gov