

WARNING

USE OF PORTER WINCHES ON PRODUCTS OTHER THAN BASKETBALL BACKSTOPS AND GYMNASIUM DIVIDER CURTAINS IS EXPRESSLY PROHIBITED.

WINCH FURNISHED COMPLETE WITH MOUNTING BRACKETS FOR 3 1/2" O.D. PIPE. (OTHER ARRANGEMENTS ARE AVAILABLE.)

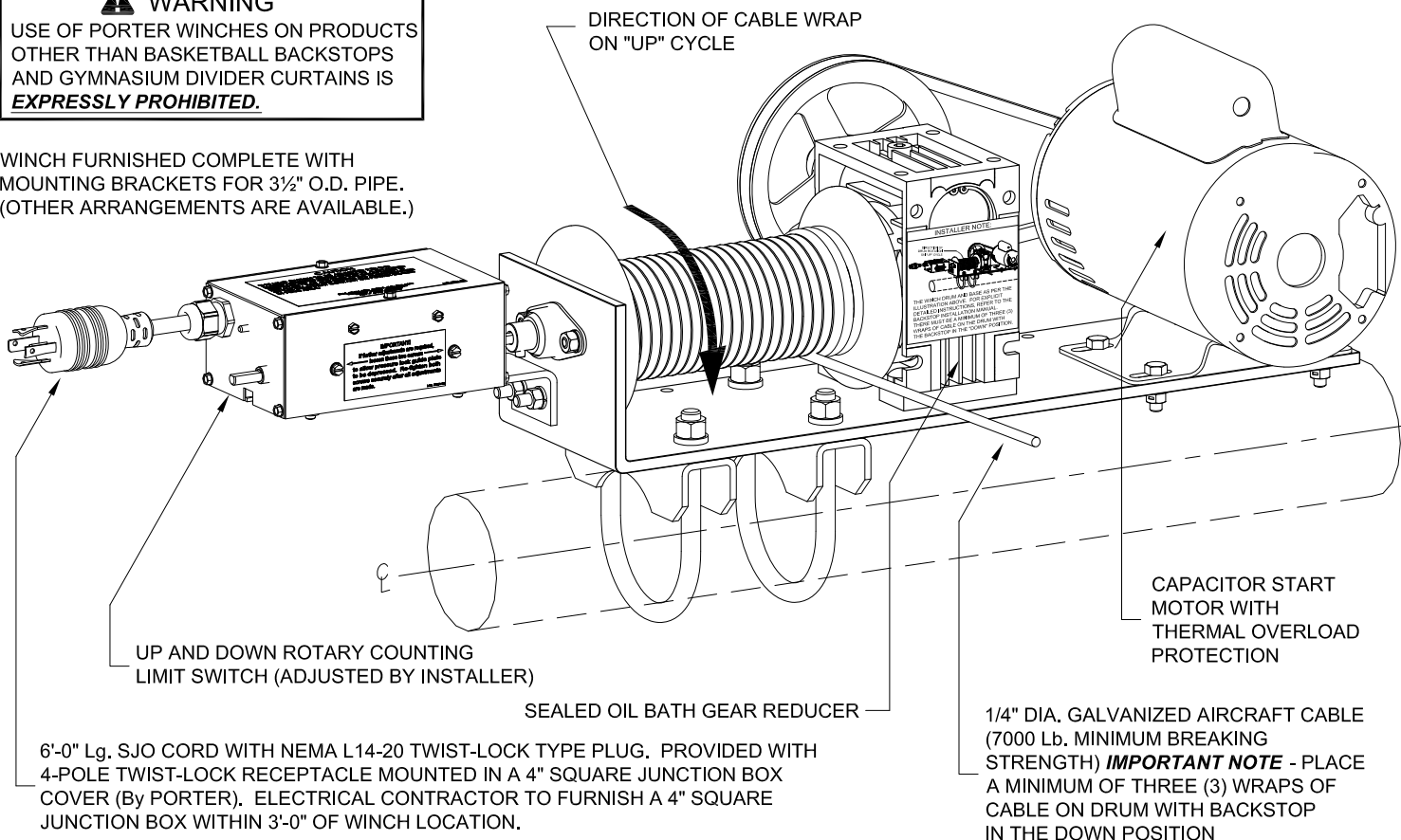

6'-0" Lg. SJO CORD WITH NEMA L14-20 TWIST-LOCK TYPE PLUG. PROVIDED WITH 4-POLE TWIST-LOCK RECEPTACLE MOUNTED IN A 4" SQUARE JUNCTION BOX COVER (By PORTER). ELECTRICAL CONTRACTOR TO FURNISH A 4" SQUARE JUNCTION BOX WITHIN 3'-0" OF WINCH LOCATION.

1/4" DIA. GALVANIZED AIRCRAFT CABLE (7000 Lb. MINIMUM BREAKING STRENGTH) **IMPORTANT NOTE** - PLACE A MINIMUM OF THREE (3) WRAPS OF CABLE ON DRUM WITH BACKSTOP IN THE DOWN POSITION

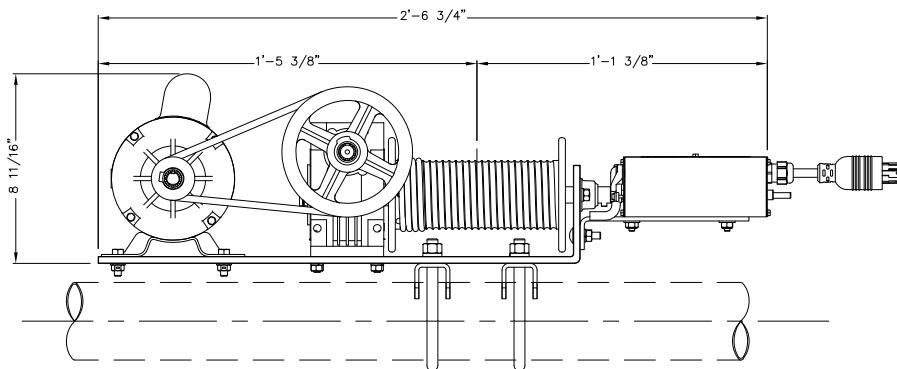
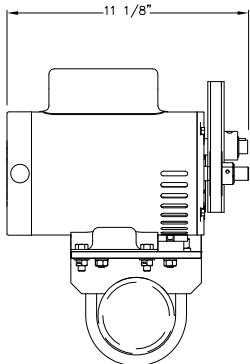

- _____ – 00806-000 1/2 H.P. ELECTRIC WINCH
- _____ – ELEC000470G0 COVER PLATE FOR RECEPTICAL
- _____ – ELEC00042100 RECEPTICAL

INDICATE TYPE OF CONTROL FOR WINCH. SEE THE FOLLOWING PAGES FOR SPECIFICATIONS AND FIELD WIRING DETAILS FOR EACH CONTROL SYSTEM.

- See E-791 – No. 791 KEY SWITCH CONTROL
KEY SWITCH CONTROL PROVIDED AS STANDARD (XELE00791112), UNLESS OPTIONAL CONTROL SYSTEM (LISTED BELOW) IS SPECIFIED
- See E-2002 – No. 2002 SPORTSONIC® II RADIO CONTROL SYSTEM
- See E-2002-5 – No. 2002 SPORTSONIC® II DUAL-MODE RADIO CONTROL / KEY SWITCH SYSTEM
- See E-2500 – No. 2500 POWR-TOUCH® KEY PAD CONTROL SYSTEM
- See E-2550 – No. 2550 POWR-TOUCH® II KEY PAD CONTROL SYSTEM

REVISION	DATE	Porter No.
~		
~		CUSTOMER No.
~		
DATE		
8/1/2008		

ELECTRIC WINCH
00806-000: 1/2 H.P.

THIS PRINT IS THE PROPERTY OF PORTER ATHLETIC EQUIPMENT COMPANY AND MAY NOT BE REPRODUCED WITHOUT WRITTEN PERMISSION



DRAWING BY	ZWS
CHECKED BY	TJK
PAGE No.	
	B-806

SPECIFICATIONS

PORTER No. 00806-000 1/2 H.P. ELECTRIC WINCH

Winch shall be worm gear type, designed to hold backstop at any position when raising or lowering. Winch housing and cable drum are machined from high strength ductile iron castings. The cable drum shall be grooved to provide neat and consistent cable tracking. The worm is machined from high strain tempered steel bar. All surfaces of the worm shaft are ground and the worm teeth and seal surfaces are polished after grinding for the utmost in efficiency and sealing capabilities. Worm shaft shall turn in sealed, precision thrust bearings. The shaft shall also be sealed by an additional seal on the outside of the sealed bearings.

Worm gear shall be machined from high strength forged bronze alloy for exceptional wearability and long life characteristics.

The worm and gear set to run in an oil bath within main shaft housing which is completely sealed by the worm shaft seal, and by a double lip seal around the polished cable drum shaft where it enters the housing. This unit is filled with oil at factory, and sealed for maintenance-free service.

Winch to be operated mechanically by means of a 1/2 H.P. (7 amp) capacitor type 60 cycle, 115 volt, single phase electric motor with automatic thermal overload protection manufactured to NEMA specifications. The motor shall drive the winch by means of a connecting V-belt and sprockets.

Drum shall be mechanically interconnected to a special rotary counting Up-Down limit switch assembly, which shall be mounted and pre-wired to motor as an integral part of the winch. Limit switch shall be furnished in a special, extruded aluminum housing. Adjustment of said limit switches designed to be easily made without the use of tools. Winch shall be pre-wired with a 6'-0" lg. neoprene covered cable with NEMA L14-20 twist-lock grounded type plug attached.

Specify type of control for winch:

- Key Switch control (provided as standard, unless optional control system (listed below) is specified)
- Sportsonic® II Radio Control System
- Sportsonic® II Dual-Mode Radio Control / Key Switch System
- Powr-Touch® Key Pad Control System
- Powr-Touch® II Key Pad Control System

Under no-load conditions, RPM of drum is 11.5, RPM of motor is 1725.

Hoisting capacity of No. 00806-000 1/2 H.P. winch is 1000 pounds.

Wiring of all electrical components shall be in accordance with local area codes, and in accordance with manufacturer's instructions.

All conduit, wiring, junction boxes and components not specified herein shall be furnished and installed by the electrical contractor.